

## POLYGONAL HIGHMASTS

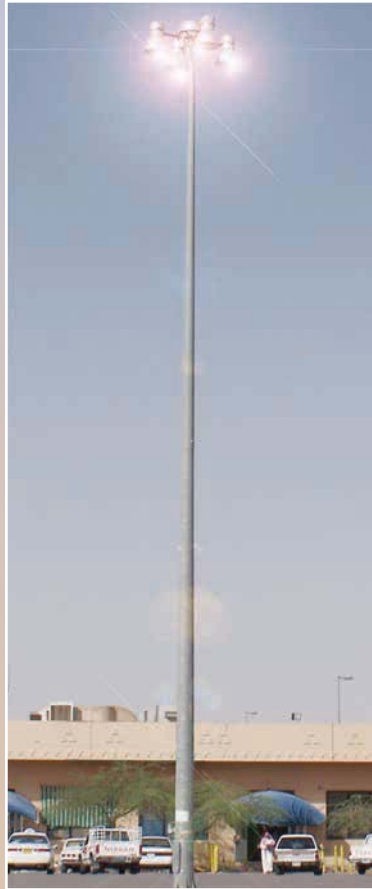

*\* Polygonal Highmasts*

*\* With Raising & Lowering Devices*



## POLYGONAL HIGHMASTS

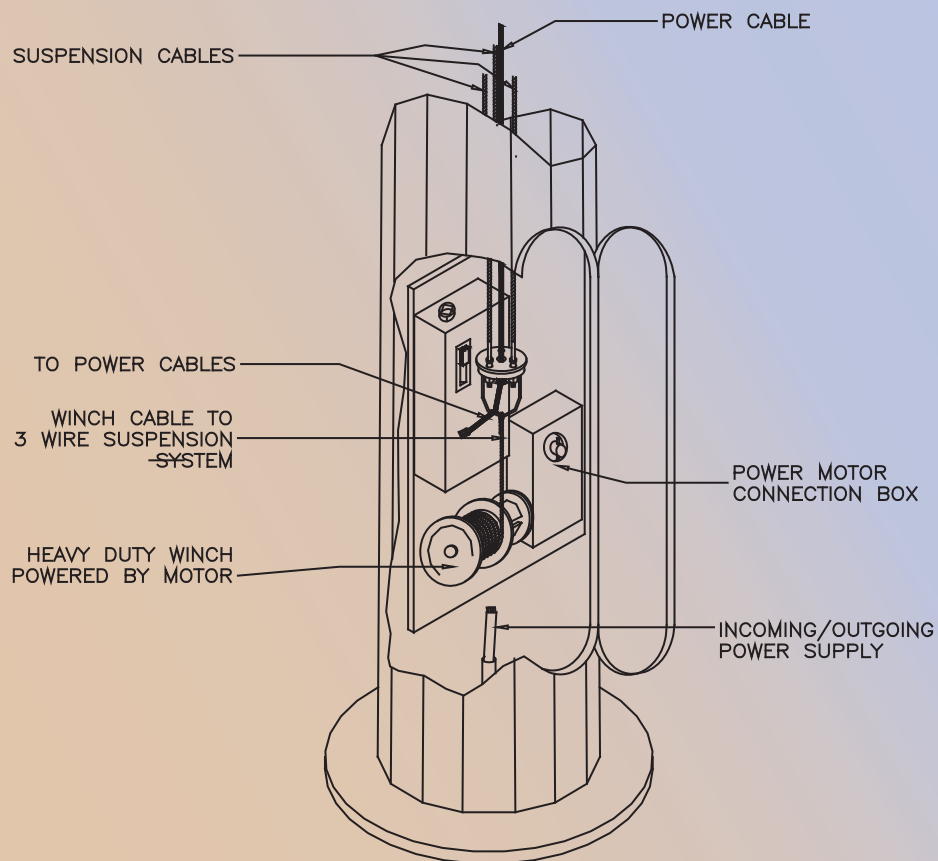
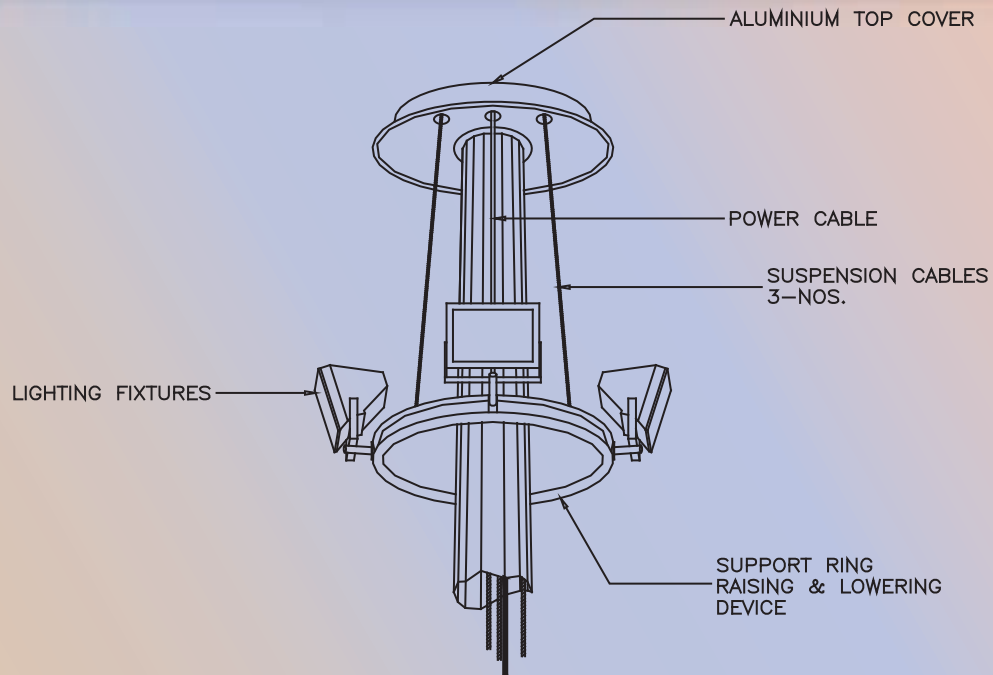

General System of Operation of a Raising & Lowering Device for High Masts

## POLYGONAL HIGHMASTS

Highmasts are ideally suitable for the lighting of wide areas like sport ground, stadia, highways, highway interchanges, Airports, Harbours, open parking lots etc.

Highmasts are manufactured from 8 to 50 Metre or above and are polygonal in shape with continuous tapered steel electrically welded. The mast is an assembly of 2-4 shafts joined together by means of pressure overlapping, section per section, rendering firm grip and are joined by telescopic slings.

Masts are designed according to the technical report No. 7 of the Association of Public Lighting Engineers, London. They are designed to withstand a specified gust wind velocity blowing in the most unfavourable direction at a height of 10 Metre above ground level and it is ensured that oscillations are damped to a minimum to avoid its failure due to fatigue.

Rectangular and tilted headframes are normally used for the highmasts which are accessed to the top by means of removable steps or caged ladder. Mobile circular type of headframes are used for highmasts with raising and lowering devices. In this case a hoisting unit is used to raise and lower the circular headframes. The raising and lowering device for circular head frame carrying lighting fixtures consists of :

- Winch with handle
- Winch cable to 3-wire suspension system
- Power cable
- Top crown
- Lighting fixtures support ring
- Junction box
- Power cable sheave
- Power tool

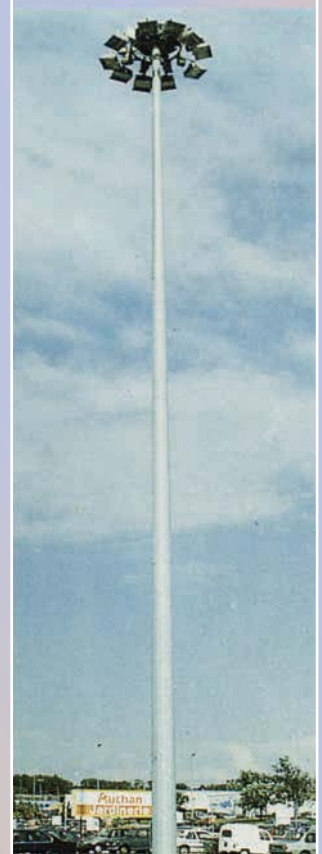
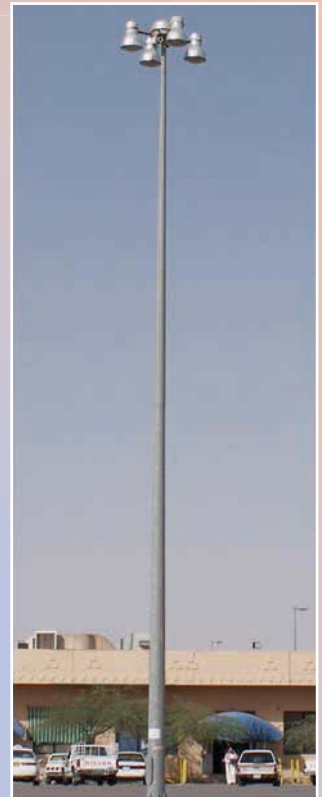

## POLYGONAL HIGHMASTS

Polygonal Highmasts from 8 Metre height and over, optionally available with raising and lowering devices are normally used for lighting Expressways, Stadia, Harbours, big open parking lots etc. The Highmast is an assembly of 2-4 shafts joined together by means of pressure over-lapping, section per section, rendering firm grip and are joined by telescopic slings.

Following are some standard sized highmasts :

Highmast Size (mm)						
"H"	"d1" (a/f)	"d2" (a/f)	"h1 x T1"	"h2 x T2"	"h3 x T3"	"h4 x T4"
8,000	150	430	8000 x 4	--	--	--
12,000	161	440	12000 x 4	--	--	--
15,000	161	440	10000 x 4	5600 x 4	--	--
16,000	161	440	10000 x 4	6600 x 4	--	--
18,000	161	440	10000 x 4	8700 x 4	--	--
20,000	161	440	10000 x 4	10800 x 4	--	--
25,000	161	475	10800 x 4	10000 x 4	5600 x 4	--
30,000	161	500	9600 x 5	11000 x 4	11000 x 4	--
35,000	161	610	9600 x 6	11000 x 5	11000 x 4	5600 x 4
38,000	200	650	11000 x 6	11000 x 5	11000 x 4	7500 x 4
40,000	200	650	11000 x 6	11000 x 5	11000 x 4	9500 x 4

Mast	Door Opening			Flange/Base Plate Size (mm)						Anchor Bolts (mm)		
	"A"	"B"	"C"	"D"	"E"	"F"	"K"	"G"	"M"	"P x Q"	"N"	"Qty"
8,000	600	1000	300	700	580	35	30	32	10	30 x 940	160	6
12,000	600	1000	300	750	620	35	30	32	10	30 x 940	160	8
15,000	600	1000	300	750	620	35	30	32	10	30 x 940	160	8
16,000	600	1000	300	750	620	35	35	32	10	30 x 940	160	8
18,000	600	1000	300	750	620	35	35	32	10	30 x 940	160	8
20,000	600	1000	300	750	620	35	35	32	10	30 x 940	160	10
25,000	600	1000	300	750	620	35	35	32	10	30 x 940	160	12
30,000	600	1000	300	800	680	35	40	32	14	30 x 940	160	16
35,000	600	1000	300	1000	850	35	50	32	15	30 x 940	160	18
38,000	600	1000	300	1050	900	35	50	32	15	30 x 940	160	20
40,000	600	1000	300	1050	900	35	50	32	15	30 x 940	160	20



## POLYGONAL HIGHMASTS

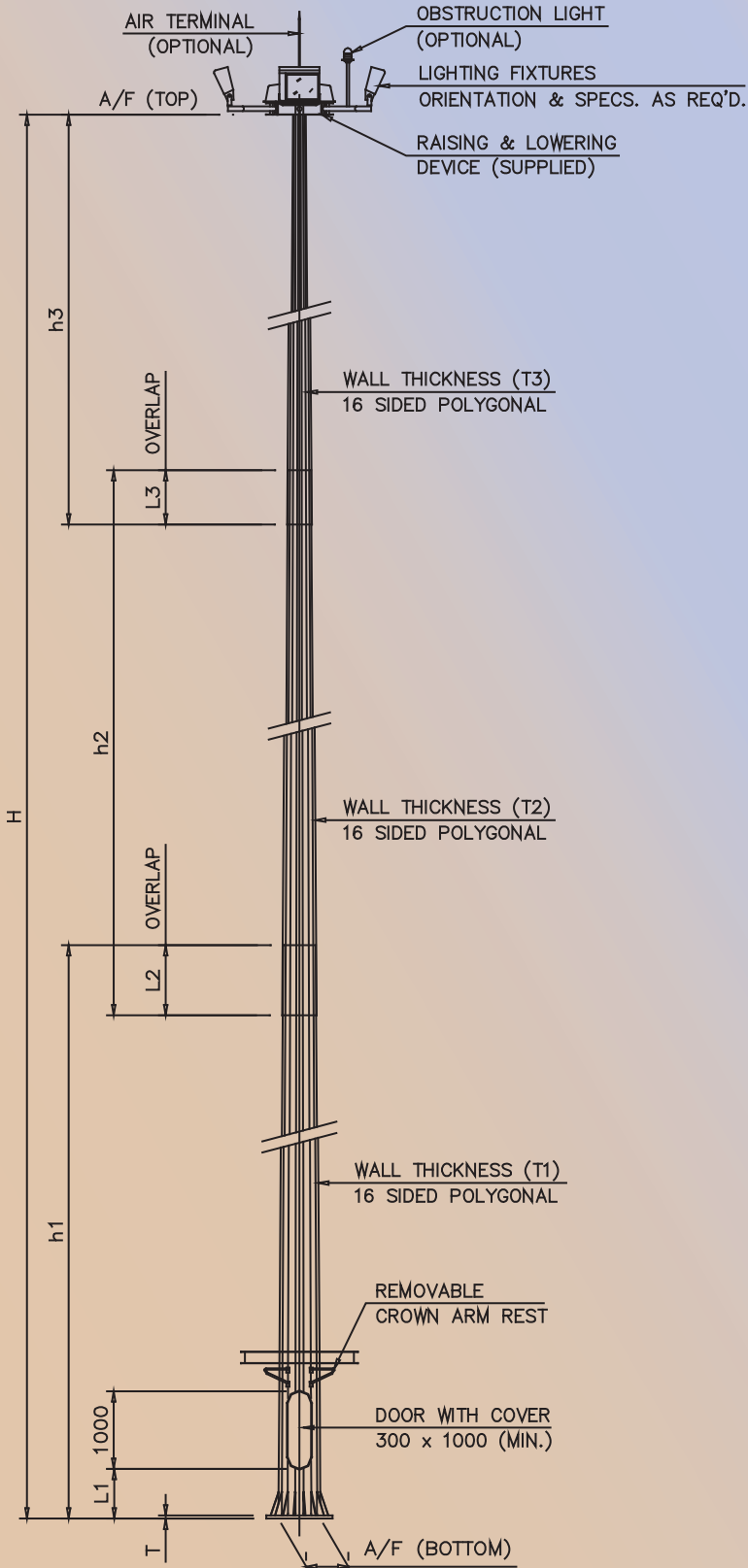

Typical Polygonal Highmast

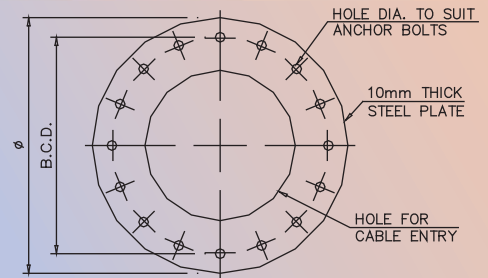

Foundation Template

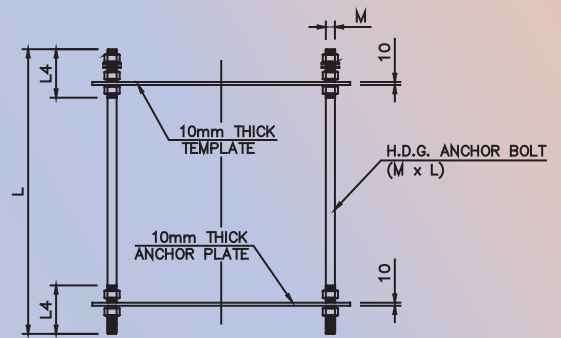

Foundation Bolt Frame

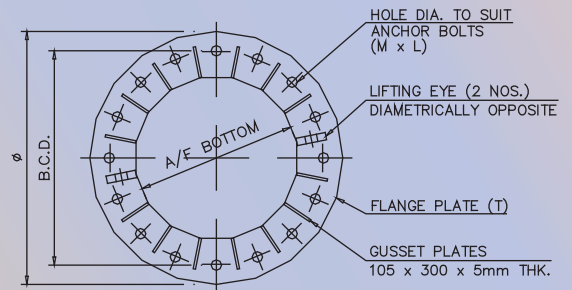

Base Plate Detail

Abbreviations :

- l) Highmast :
- H = Overall height
  - h1 = Size of bottom shaft
  - h2 = Size of middle shaft
  - h3 = Size of top shaft
  - T = Base Plate Thickness

Notes :

1. All dimensions are in mm
2. Finish : Hot dip galvanized to BS ISO 1461 (or as specified).
3. Accessories are made of Mild Steel Grade.
4. Shaft made of Steel Grade FE 510C (According to EN 10025).